

Power supply modul for sensors vario CO 2/U

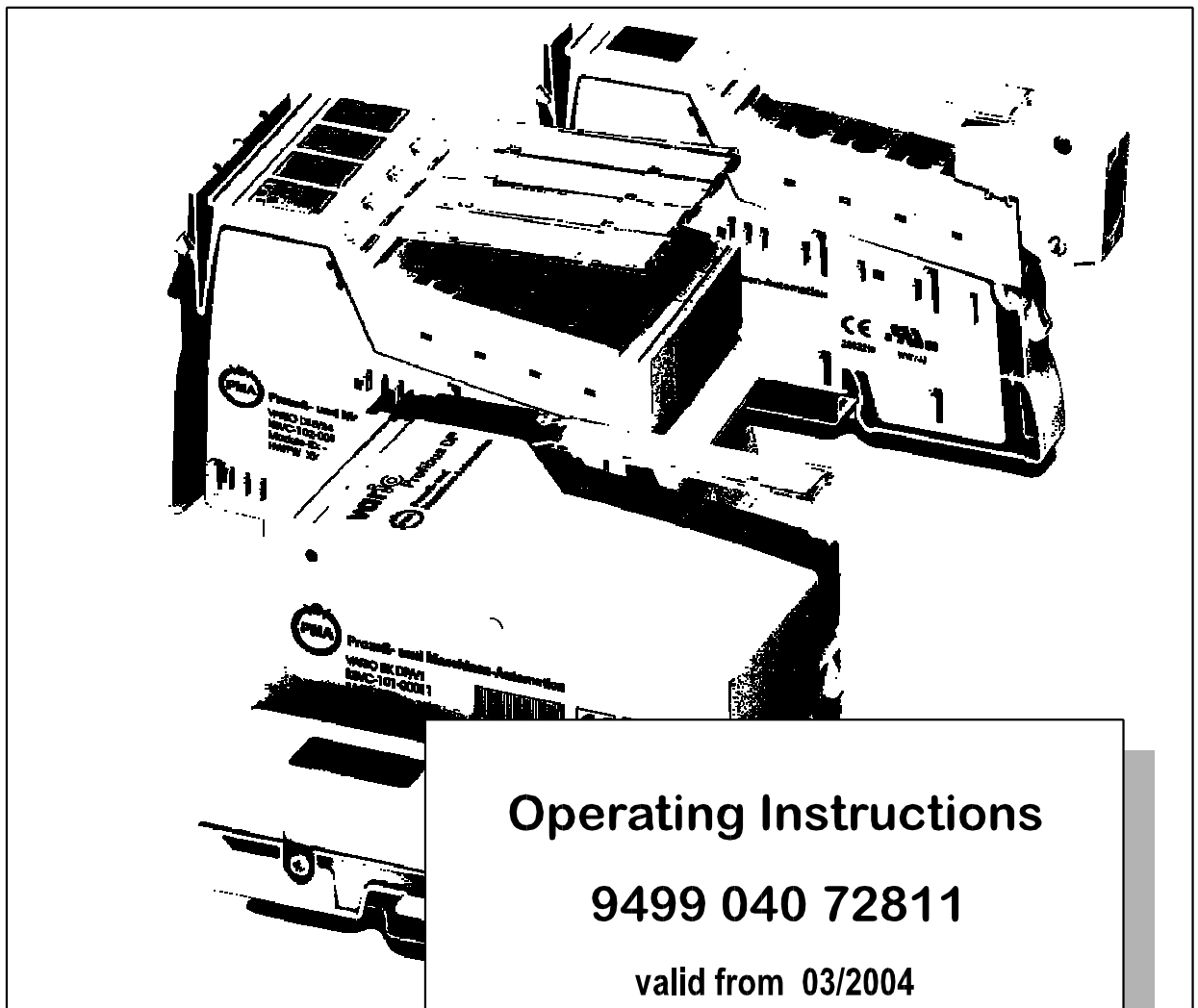

Operating Instructions

9499 040 72811

valid from 03/2004

©PMA Prozeß- und Maschinen-Automation GmbH 2004. Printed in Germany
All rights reserved. No part of this document may be
reproduced or published in any form or by any means without prior written permission
by the copyright owner.

A publication of PMA Prozeß- und Maschinen-Automation GmbH

Subject to change without notice.

PMA Prozeß- und Maschinen-Automation GmbH
P.O. Box 31 02 29
D 34058 Kassel
Germany

Restriction of warranty:

No warranty is given for the complete correctness of this manual, since errors can never avoided completely despite utmost care. Any hints are welcome and gratefully accepted.

1 General

The vario power supply module for sensors is used for energizing transmitters, especially strain gauge or semi-conductor bridges for pressure sensors within the KS vario/vario system.

The module provides a supply voltage for pressure sensors, which is isolated from the remaining system.

Power supply module for sensors, VARIO CO 2/U, order no. KSVC-103-02221

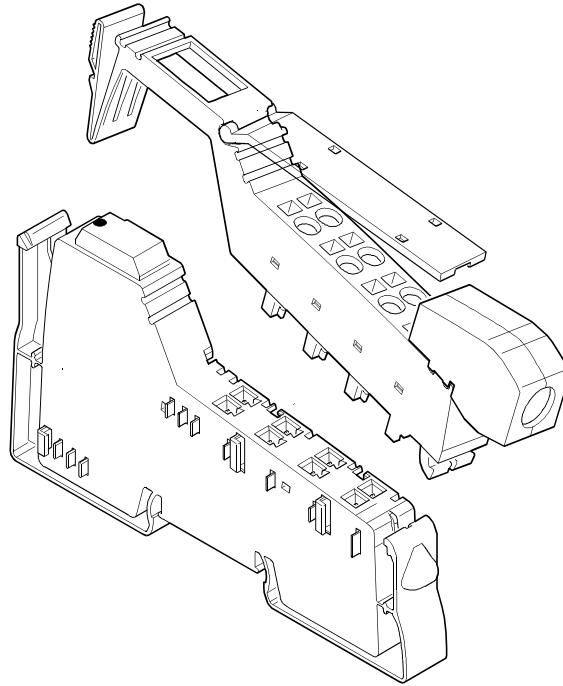

2 Technical data:

Supply voltage:	24 V d.c. (from the analog voltage (U_{ana}) of the vario station.
Current consumption:	approx. 120 mA
Output voltage:	2 x 10 V d.c. constant voltage outputs for energization of 1 or 2 strain gauge pressure sensors
Output current:	2 x 40 mA or 1 x 80 mA. The sum must not exceed 80 mA.
Accuracy:	typ. 0,6 %
Drift:	typ. 0,3 %
Short circuit protection:	max. 1 h
Galvanic isolation:	isolated from the supply voltage (U_{ana}), outputs galvanically connected.
Display element:	1 LED, yellow, for indication of the output voltage
Connection technique:	cage clamp, 2-wire connection with screening
Dimensions:	12,2 x 120 x 76 mm
Weight:	approx. 70 g

Temperature range:	operation: -25 °C to 55°C	storage/transport: -25 °C to 85 °C
Humidity:	operation/storage/transport: average 75 %, 85 % occasional	
Protection type:	IP20 to IEC 60529	
Bus Interface:	not required, however, the internal bus is looped through the module.	
Accessories:	connector, inscription field (delivered with the unit)	

3 Pin allocation and elementary circuit diagram

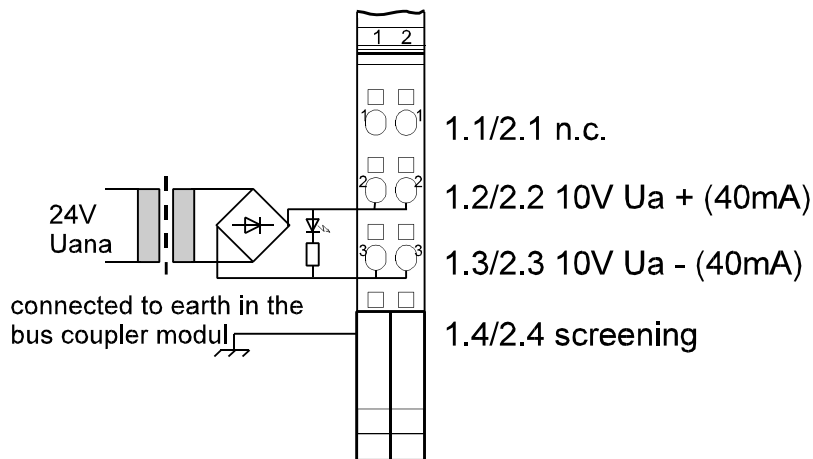

The screening earth connection must be made via the **function earth (FE)**. The screening is connected to earth only with a non-interrupted connection up to the bus coupler module provided. (The function earth is looped through all modules and connected to earth centrally at the bus coupler module.)

4 Pressure sensor connection

Normally, pressure sensors consist of a full bridge circuit which must be energized by a voltage galvanically isolated from the system. The diagonal voltage is applied to a controller module input (mV), which is configured accordingly.

Sensor calibration is by means of a built-in resistor of a defined value in the pressure sensor. Without pressure applied, the resistor changes the bridge resistance so that 80 % nominal output voltage are available at its output. The relevant values are given in the pressure sensor data sheet. This resistance can be connected in parallel to a bridge arm by an external relay, whereby a detuning of the bridge is caused.

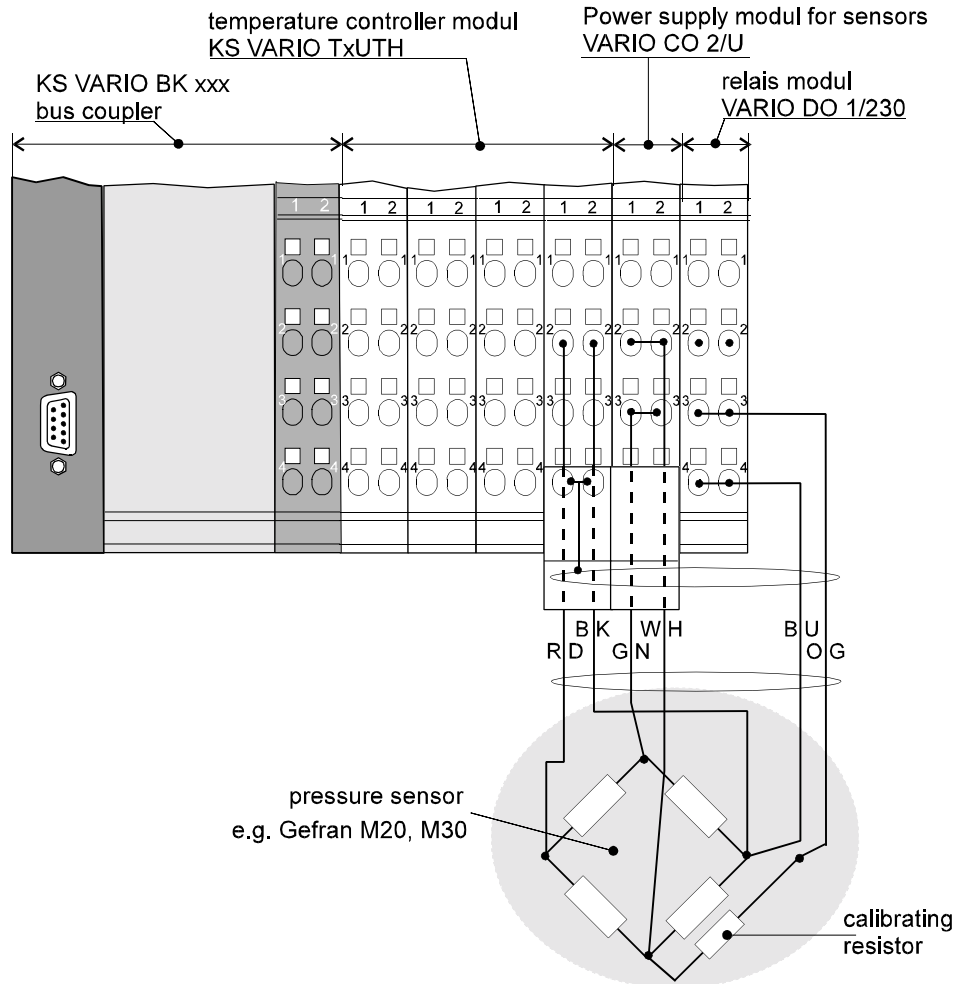

The following relay modules are provided:

VARIO relay output module VARIO DO 1/230, order no. K SVC-102-01211 or VARIO relay output module VARIO DO 4/230, order no. K SVC-102-01231.

These modules permit control of the relay, i.e. bridge resistance change, via the system bus. When using these relay modules, the following information must be taken into account: For using the module for switching the calibrating resistor, the only load must be the calibrating resistor. The sparks generated by higher currents/voltages cause contact consumption and increase the contact resistance, i.e. correct switching of a "dry circuit" is not ensured any more.

The relay modules should be always at the right end of a KS vario station. In these modules, the voltage U_b and U_s (both 24V) are interrupted. Consequently, these voltage would have to be fed in again behind the relay module.

The connector of a relay module (colour: median gray) must not be plugged into other modules, because when using for purposes varying from the "calibrating relay", higher voltages (230 V AC) may also be applied to the contacts. These can destroy the components of the contacted module components unless plugged in correctly.

Although this connector is coded mechanically for protection against being inserted completely into other modules by closing of contact holes 1.1 and 2.1, electrical connections can occur even with partial faulty connection.

For extending the cable fitted to the pressure sensor, the same or a very similar cable type must be used (6-wire, screened).

5 Maintenance and behaviour in case of fault

The power supply module for sensors and the relay module do not need particular maintenance and no components require any preventive maintenance or care.

5.1 Trouble shooting

To start with, all possibilities of trouble sources due to connected instruments and cables (input leads, wiring, equipment connected in the output circuit) should be checked. Unless the trouble was found after these checkings, the instrument must be returned to the manufacturer:

PMA Prozeß- und Maschinen-Automation GmbH
Service-Abteilung
Miramstraße 87
D 34123 Kassel

If the trouble is found to be due to failure of a fuse, the cause must be determined and corrected. The spare fuse must have the same rating as the original type.

Unless the LED is lit despite intact fuse and correctly connected supply voltage, the bus coupler is defective and must be returned to the manufacturer for repair.

5.2 Shut-down

Before disconnecting the unit, disconnect the system completely from the supply voltage and check that other equipment connected in the overall system is not effected.

WARNING!

When the instrument is suspected of being unsafe, it must be taken out of operation and protected against accidental switch-on.

WARNING!

5.3 Customer Support Hotline

For further questions beyond the scope of the KS 800 operating manual, please, contact one of the following telephone numbers from Monday to Friday, between 8 a.m. and 16 p.m.

Tel. Customer Support:	49 561 505 3091
Tel. Repair:	49 561 505 1257
Tel. Sales Dept.:	49 561 505 1307
e-mail:	mailbox@pma-online.de

