

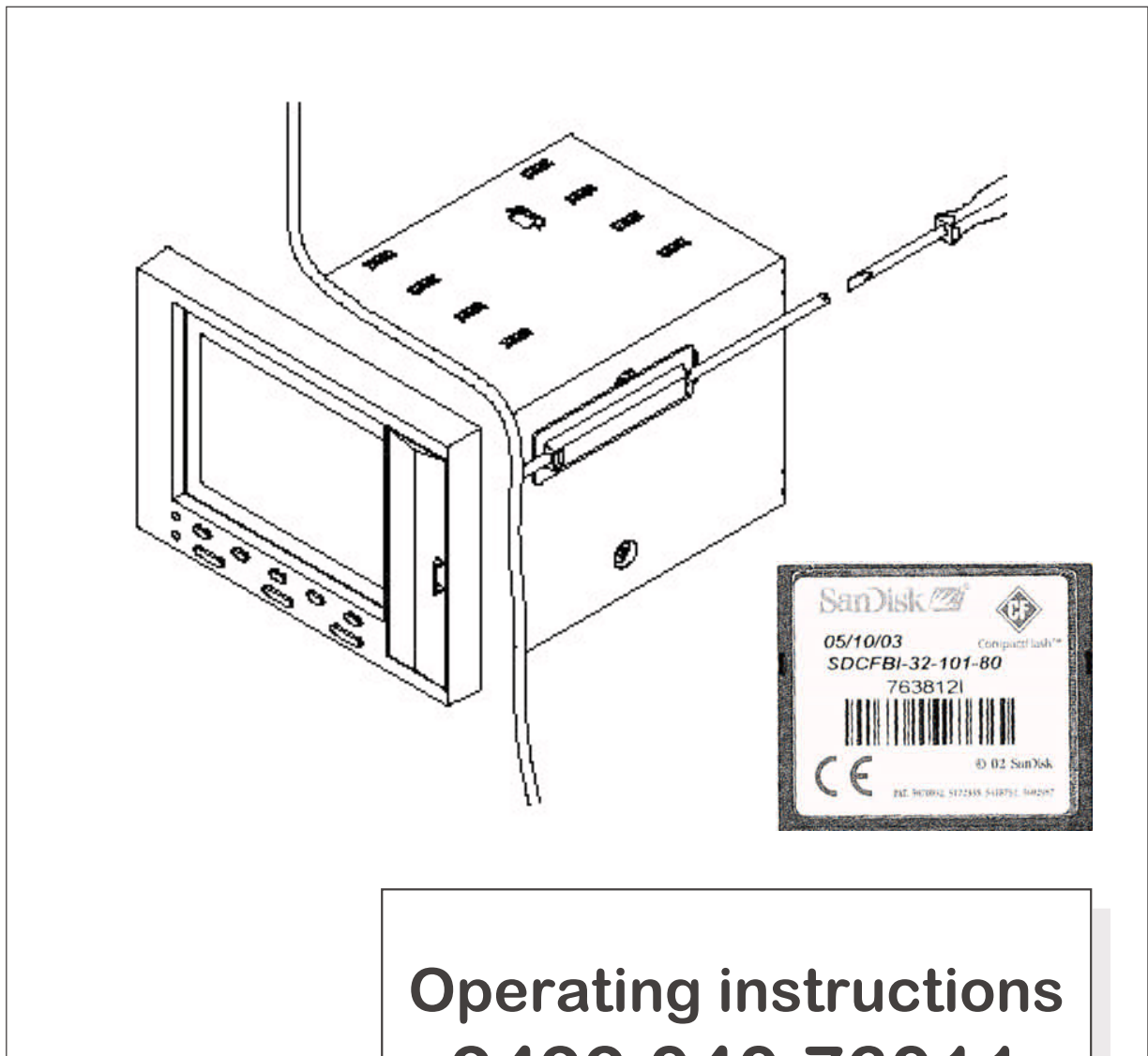

KS3012

Data Monitor with Compact Flash Install instructions



Operating instructions

9499 040 76011

valid from/valable depuis:8420

Menu structure of the paperless recorder

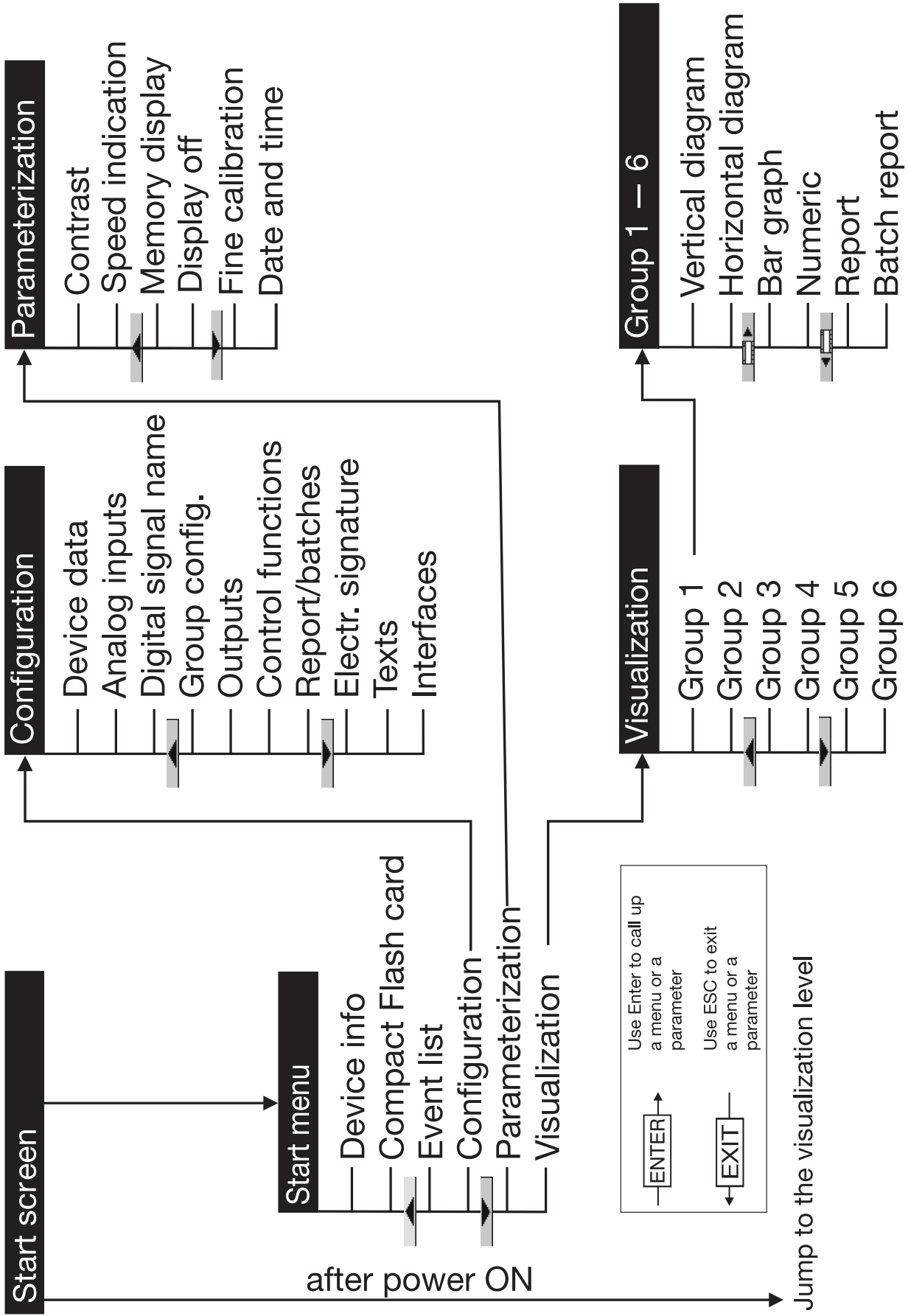

Contents

| | | |
|----------|---|-----------|
| 1 | Introduction | 5 |
| 1.1 | Preface | 5 |
| 1.2 | Arrangement of the documentation | 6 |
| 1.3 | Typographical conventions | 7 |
| 2 | Identifying the instrument version | 9 |
| 2.1 | Nameplate | 9 |
| 2.2 | Type designation | 10 |
| 2.3 | Standard accessories | 11 |
| 2.4 | Accessories | 11 |
| 3 | Installation | 13 |
| 3.1 | Location and climatic conditions | 13 |
| 3.2 | Mounting in position | 13 |
| 4 | Electrical connection | 15 |
| 4.1 | Installation notes | 15 |
| 4.2 | Procedure | 16 |
| 4.3 | Connection diagram | 17 |
| 5 | Function check | 21 |
| 6 | Device replacement / software update | 23 |
| 7 | Technical data | 25 |
| 8 | Index | 29 |

Contents

1.1 Preface



Please read this Operating Manual before commissioning the instrument. Keep the manual in a place that is accessible to all users at all times.

Please assist us to improve this operating manual, where necessary.

Your suggestions will be appreciated.



However, if any difficulties should arise during start-up, please do not carry out any manipulations. You could endanger your rights under the instrument warranty!

Please contact the nearest subsidiary or the head office in such a case.



When returning modules, assemblies or components, the regulations of EN 61340-5-1 and 61340-5-2 "Protection of electronic devices from electrostatic phenomena" must be observed. Use only the appropriate **ESD** packaging for transport.

Please note that we cannot accept any liability for damage caused by ESD.

ESD=electrostatic discharge

1 Introduction

1.2 Arrangement of the documentation

The documentation for this instrument is addressed to equipment manufacturers (OEMs) and users with appropriate technical expertise. It consists of the following parts:

Instrument documentation in printed form

Operating Instructions 9499-040-76211

The operating instructions are an extract from the operating manual and cover the basic operation of the paperless recorder.

Installation Instructions 9499-040-76011

The installation instructions describe the installation of the recorder and the connection of the supply and signal cables. The instructions also contain a list of the technical data.

Instrument documentation in the form of PDF files

The “Instrument documentation in the form of PDF files” is on the CD that comes with the delivery.

Operating Manual 9499-040-76111

It contains information about commissioning, operation and parameterization on the instrument, as well as about the PC setup program (available as an option).

Operating Instructions 9499-040-76211

The operating instructions are an extract from the operating manual and cover the basic operation of the paperless recorder.

Interface Description (serial interfaces) 9499-040-76311

This provides information on the communication (RS232; RS422/RS485) with supervisory systems.

Interface Description (Ethernet interface)

This provides information on the connection of a paperless recorder to a company-internal network. The description is integrated in the 9499-040-76311.

Interface Description (PROFIBUS-DP interface) 9499-040-76511

This provides information on the connection of a paperless recorder to a PROFIBUS-DP system.

Installation Instructions 9499-040-76011

The installation instructions describe the installation of the recorder and the connection of the supply and signal cables. The instructions also contain a list of the technical data.

1.3 Typographical conventions

Warning signs

The symbols for **Danger** and **Caution** are used in this manual under the following conditions:



Danger

This symbol is used when there may be **danger to personnel** if the instructions are ignored or not followed correctly!



Caution

This symbol is used when there may be **damage to equipment or data** if the instructions are ignored or not followed correctly!



Caution

This symbol is used where special care is required when handling **components liable to damage through electrostatic discharge**.

Note signs

Note



This symbol is used when your **special attention** is drawn to a remark.

Reference



This symbol refers to **further information** in other manuals, chapters or sections.

Footnote

abc¹

Footnotes are remarks that **refer to specific points** in the text. Footnotes consist of two parts:

A marker in the text, and the footnote text.

The markers in the text are arranged as continuous superscript numbers.

Action

*

This symbol indicates that an **action to be performed** is described.

The individual steps are marked by this asterisk, e.g.

* Press the  key

* Confirm with 

1 Introduction

2 Identifying the instrument version

2.1 Nameplate

Identification

Position The nameplate is affixed to the paperless recorder.

Contents It contains important information such as:

| Description | Designation on nameplate | Example |
|-------------------|---|--|
| Instrument type | Typ | 9407-303-11021 |
| Sales number | VARTN | 95/00342163 |
| Production number | F-Nr | 0022969000004180006 |
| Supply voltage |  | AC 110 ... 240V +10/-15%, 48...63Hz |

Typ Please compare the type that was supplied with your order details. You can identify the type by referring to Chapter 2.2 “Type designation”.

VARTN The sales number unambiguously designates the article in the catalog. It is used for communication between the development and the manufacturing.

F-Nr The production number indicates the production date (year/week). The figures concerned are in position 12, 13, 14, 15.

Example:

F-Nr 002296900000**4180006**

This shows that the paperless recorder was manufactured in 2004, week 18.

2 Identifying the instrument version

2.2 Type designation

| Datamonitor KS 3012 paperless recorder | | | | | | | | | |
|---|-----------------|--------|----------------|-----------|---------|-----------------|--------------|-----|--|
| | Basic version | Inputs | extern. Memory | Interface | Options | internal memory | carring case | | |
| Order number | | | | | | | | | |
| Paperless Recorder with CompactFlash card as storage medium | 9407-303 | - | x | x | x | x | x | (x) | |
| Inputs | | | | | | | | | |
| 6 analog inputs | | | x | | | | | | |
| 12 analog inputs | | | 1 | | | | | | |
| paperless recorder without analog inputs (for Profibus-DP) | | | 2 | | | | | | |
| 6 analog inputs stainless steel front with membrane keys IP65 | | | 3 | | | | | | |
| 12 analog inputs stainless steel front with membrane keys IP65 | | | 4 | | | | | | |
| without analog inputs (for Profibus-DP) stainless steel front with membrane keys IP65 | | | 5 | | | | | | |
| External memory | | | | | | | | | |
| without external memory | | | | x | | | | | |
| 32 MB CompactFlash memory card | | | | 1 | | | | | |
| 64 MB CompactFlash memory card | | | | 2 | | | | | |
| 128 MB CompactFlash memory card | | | | 3 | | | | | |
| Interface | | | | | | | | | |
| RS232 (Standard) | | | | | | | | | |
| RS422/485 | | | | | 1 | | | | |
| RS232 and Profibus DP | | | | | 2 | | | | |
| RS422/485 and Profibus DP | | | | | 3 | | | | |
| RS232 (Standard) + Ethernet | | | | | 4 | | | | |
| RS422/485 + Ethernet | | | | | 5 | | | | |
| RS232 and Profibus DP + Ethernet | | | | | 6 | | | | |
| RS422/485 and Profibus DP + Ethernet | | | | | 7 | | | | |
| Supply and options | | | | | | | | | |
| AC 110..240 V | | | | | | | | | |
| AC/DC 20..30V | | | | | | 1 | | | |
| AC 110..240 V + logic inputs- and outputs (1) | | | | | | 2 | | | |
| AC/DC 20..30V + logic inputs- and outputs (1) | | | | | | 3 | | | |
| AC 110..240 V + storage capacitor (2) | | | | | | 4 | | | |
| AC/DC 20..30V + storage capacitor (2) | | | | | | 5 | | | |
| AC 110..240 V + logic inputs- and outputs (1) + storage capacitor (2) | | | | | | 6 | | | |
| AC/DC 20..30V + logic inputs- and outputs (1) + storage capacitor (2) | | | | | | 7 | | | |
| Internal memory | | | | | | | | | |
| 32 MB Backup-memory | | | | | | | 1 | | |
| 64 MB Backup-memory | | | | | | | 2 | | |
| 128 MB Backup-memory | | | | | | | 3 | | |
| (1) 7 logic inputs, 1 open-collector output., 4 relay outputs, voltage output 24V DC 50mA | | | | | | | | | |
| (2) storage capacitor instead of lithum battery for memory buffer | | | | | | | | | |
| supplementary accessory | | | | | | | | | |
| Universal carring case addendum H1 | 9407-301 | - | 9 | 0 | 0 | 3 | 1 | H1 | |
| Software | | | | | | | | | |
| Order number | 9407-303 | - | x | 0 | x | x | 1 | | |
| PCA 3000 evaluation software | | | 9 | 0 | 2 | 0 | 1 | | |
| PCC Kommunikations-Server | | | 9 | 0 | 2 | 1 | 1 | | |
| Engineering Tool KS3012 (Setup-software) | | | 9 | 0 | 2 | 2 | 1 | | |

2 Identifying the instrument version

2.3 Standard accessories

- 1 Installation Instructions
- 1 Operating Instructions
- 2 mounting brackets
- 4 cable-tie with foot (can be released)
for strain relief of the sensor connection cables
- 1 CD with additional documentation
(see Chapter 1.2 “Arrangement of the documentation”)

2.4 Accessories

- Setup program
- PC Evaluation software (PCA3000)
- PCA Communications software (PCC)
- PC interface cable with TTL/RS232 converter and adapter,
for setup program, Sales No. 9407-301-90111

2 Identifying the instrument version

3.1 Location and climatic conditions

The location should be as free as possible from shock and vibration. Stray electromagnetic fields from motors, transformers etc. should be avoided.

The ambient temperature at the location can be 0 to +45°C, at a relative humidity of $\leq 75\%$, no condensation.

⇒ Chapter 4.1 “Installation notes”

3.2 Mounting in position

Outline drawings

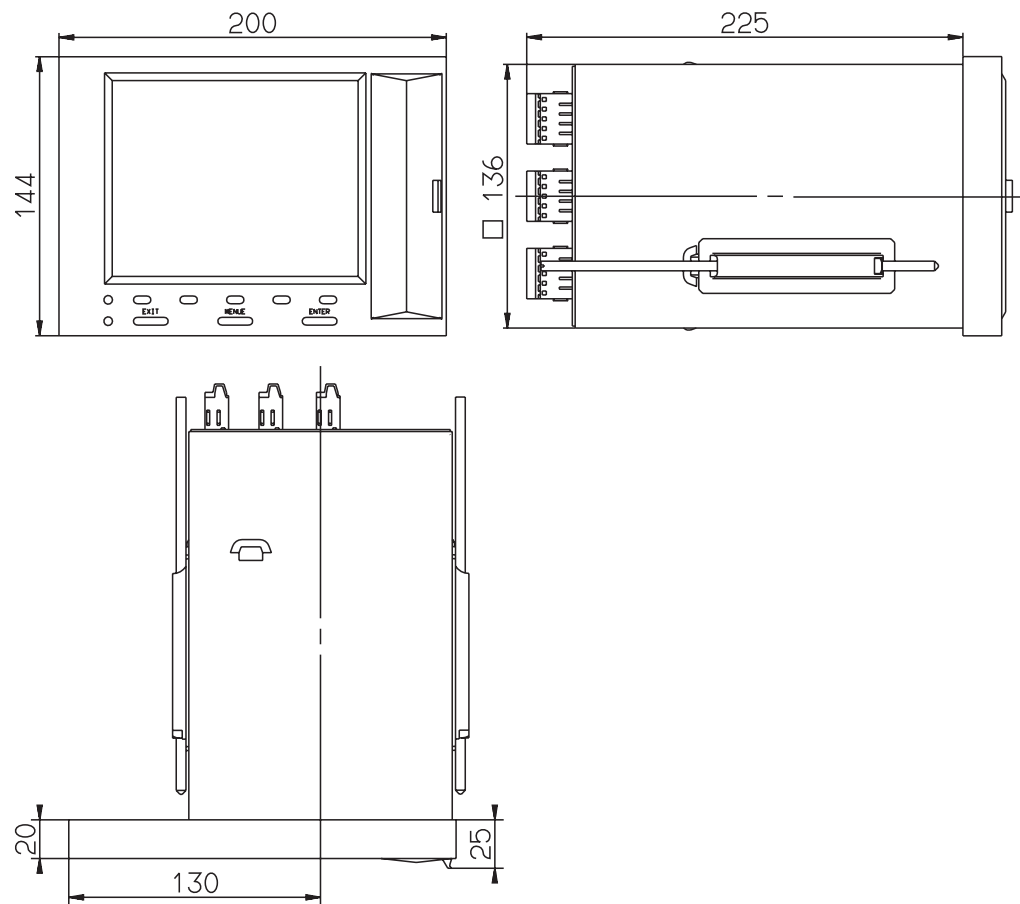

Stainless steel front

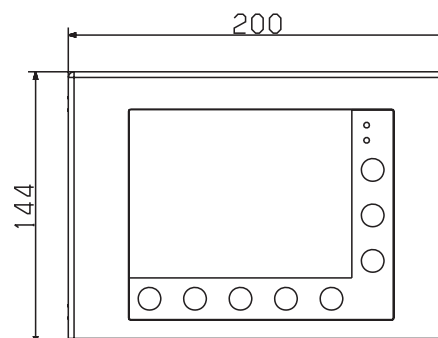

3 Installation

Fitting into the panel

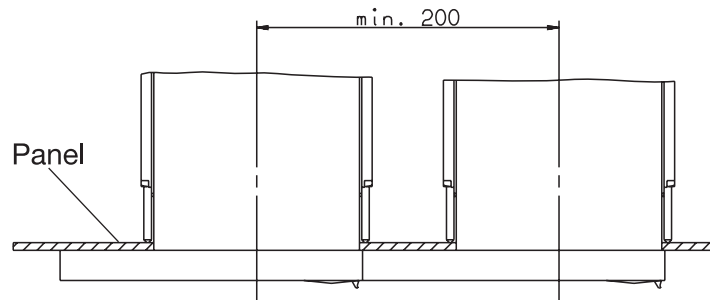

Fitting in position

- * Insert the paperless recorder from the front into the panel cut-out.
- * From the back of the panel, hook the two mounting brackets into the recesses on the sides of the housing. The flat sides of the brackets must be against the housing.
- * Place the mounting brackets against the rear of the panel and tighten them evenly.

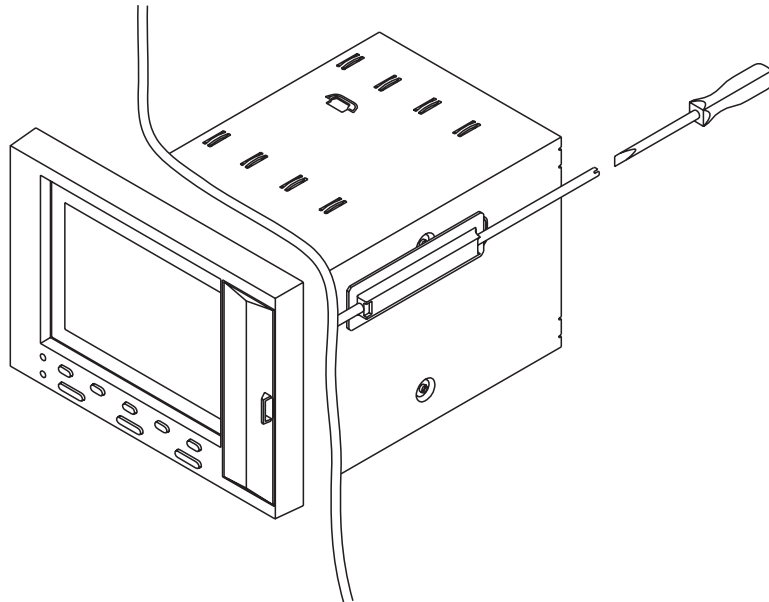

4.1 Installation notes

- The choice of the cable, the installation and the electrical connection must conform to the requirements of VDE 0100 “Regulations on the Installation of Power Circuits with nominal voltages below 1000V”, or the appropriate local regulations.
- Work inside the instrument must only be carried out to the extent described and, like the electrical connection, only by qualified personnel.
- If contact with live parts is possible while working on the instrument, it must be isolated from the supply on both poles.
- The electromagnetic compatibility (EMC) conforms to the standards and regulations listed under Technical Data.
⇒ Chapter 7 “Technical data”
- Run the input, output and supply cables separately, and not parallel to one another.
- All input and output cables without connection to the supply network must be arranged as twisted and screened cables. Earth the screen on the instrument side to the earth potential.
- Earth the instrument at the PE terminal to the protective conductor. This cable should have the same cross-section as the supply cable. Earthing cables should be run in a star layout to a common earthing point which is connected to the protective conductor of the supply. Do not loop the earthing cable, i.e. do not run it from one instrument to another.
- Do not connect any additional loads to the supply terminals of the instrument.
- The instrument is not suitable for use in hazardous areas.
- Inductive loads close to the instrument, such as contactors or solenoid valves, should have RC modules fitted for interference suppression.
- The supply to the instrument must be provided with additional fusing. Depending on the supply voltage, the following fuse values apply:

20 – 30V AC/DC, 48 – 63Hz : fuse 2A slow

110 – 240V AC +10/-15%, 48 – 63Hz : fuse 1A slow

A type-G miniature cartridge fuse marked F1 is built into the instrument itself:

20 – 30V AC/DC, 48 – 63Hz : fuse 1.6A slow

110 – 240V AC +10/-15%, 48 – 63Hz : fuse 0.63A slow

4 Electrical connection

4.2 Procedure

- * Carry out electrical connection as per Chapter 4.3 “Connection diagram”.
- * If necessary, use cable-ties for strain relief of connecting cables.

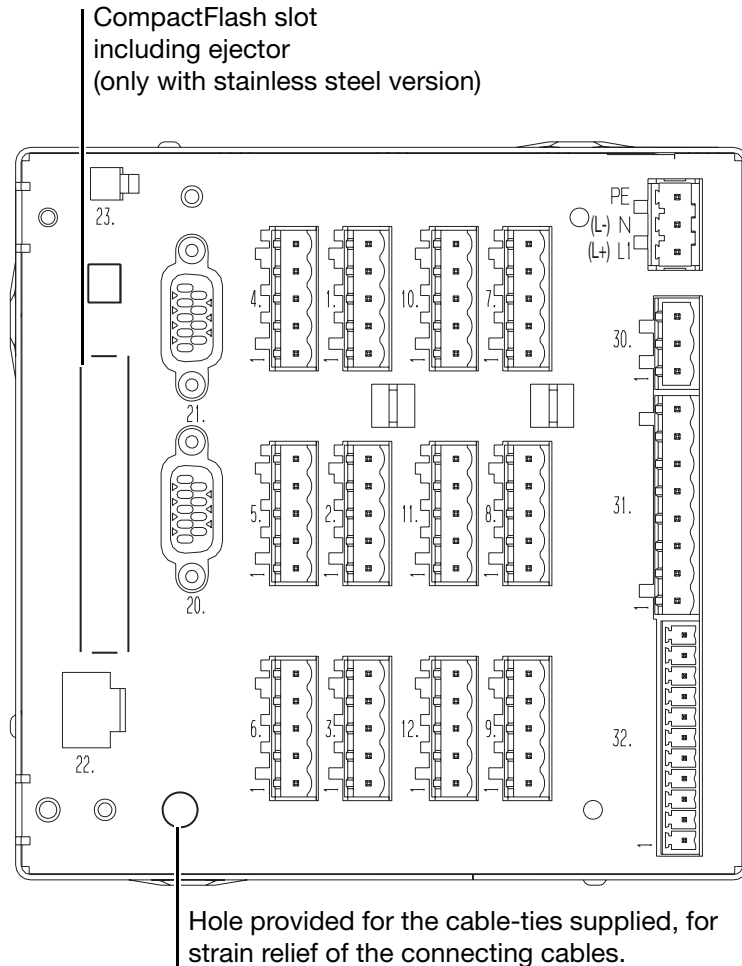

| Connector | Function |
|-----------|----------------------------|
| 1 – 12 | Analog inputs |
| 20 | RS232C or RS422 or RS485 |
| 21 | PROFIBUS-DP |
| 22 | Ethernet |
| 23 | Setup |
| 30 | Relay output |
| 31 | Relay outputs |
| 32 | Digital I/O (logic inputs) |

4 Electrical connection

4.3 Connection diagram



The electrical connection must only be carried out by qualified personnel.

Back panel

Rear view with pluggable screw terminals

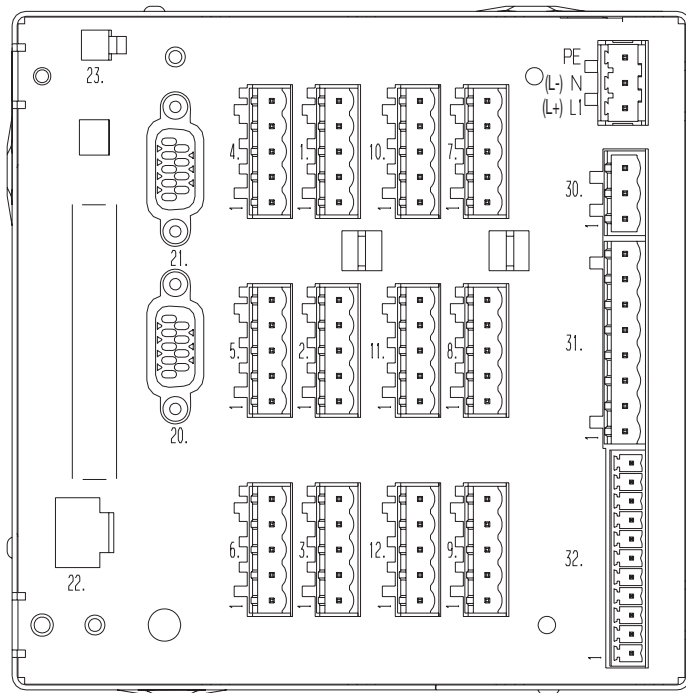



| | Terminal assignment | Connector | Connection diagram |
|---------------|---|------------------------|--------------------|
| Supply | Supply voltage as per data sheet | L1(L+) N (L-) PE | |
| | Thermocouple | 1 to 12 | |
| Analog inputs | Resistance thermometer in 2-wire circuit | 1 to 12 | |
| | Resistance thermometer in 3-wire circuit | 1 to 12 | |
| | Resistance thermometer in 4-wire circuit | 1 to 12 | |

4 Electrical connection

| | Terminal assignment | Connector | Connection diagram |
|-------------------|---|-----------|--------------------|
| | Resistance transmitter | 1 to 12 | |
| | Potentiometer in 2-wire circuit | 1 to 12 | |
| | Potentiometer in 3-wire circuit | 1 to 12 | |
| | Potentiometer in 4-wire circuit | 1 to 12 | |
| | Voltage input $\leq 200\text{mV}$ | 1 to 12 | |
| | Voltage input $> 200\text{mV}$ | 1 to 12 | |
| | Current input | 1 to 12 | |
| Interfaces | RS232C 9-pole SUB-D socket 2 RxD receive data 3 TxD transmit data 5 GND ground | 20 | |
| | RS422 9-pole SUB-D socket (extra code) 3 TxD+ transmit data + 4 RxD+ receive data + 5 GND ground 8 TxD- transmit data - 9 RxD- receive data - | 20 | |
| | RS485 9-pole SUB-D socket (extra code) 3 TxD+/RxD+ transmit/receive data + 5 GND ground 8 TxD-/RxD- transmit/receive data - | 20 | |

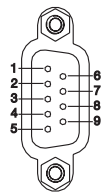
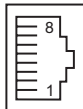
4 Electrical connection

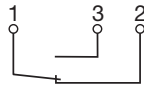
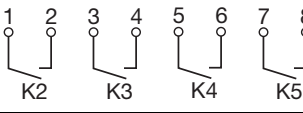
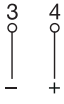
| | Terminal assignment | Connector | Connection diagram |
|---------------|--|-----------|---|
| Interfaces | PROFIBUS-DP 9-pole SUB-D socket (extra code) 3 RxD/TxD-P B-cable receive/transmit data-Plus 5 DGND data transmission potential 6 VP supply voltage-Plus 8 RxD/TxD-N A-cable receive/transmit data-N | 21 |  |
| | Ethernet RJ45 socket (extra code) 1 TX+ transmit data + 2 TX- transmit data - 3 RX+ receive data + 6 RX- receive data - | 22 |  |
| | Setup interface The recorder also has a setup interface on the front panel (wired in parallel). Do not use both at the same time. | 23 |  |
| Relay outputs | Relay K1 (changeover, 3A, 230V AC) ¹ | 30 |  |
| | Relay K2 to K5 (make/break contact, 3A, 230V AC) ¹ (extra code) | 31 |  |
| Digital I/O | 1. with resistive load. SELV circuits and supply circuits must not be combined. | | |
| | Open-collector output (25V max., 100mA max.) (extra code) 3 ground 4 collector | 32 |  |

4 Electrical connection

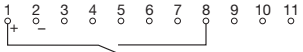
| | Terminal assignment | Connector | Connection diagram | | | | | | | | | | | | | | | | |
|--------------------|---|-----------|--|-------|----------|---|----|---|----|---|---|---|---|---|---|---|---|---|---|
| Digital I/O | Logic inputs, voltage-operated (extra code) LOW = -3 to +5V DC HIGH = 12 to 30V DC 1 +24V/50mA auxiliary supply not stabilized 2 GND 5 Logic input 7 6 Logic input 6 7 Logic input 5 8 Logic input 4 9 Logic input 3 10 Logic input 2 11 Logic input 1 | 32 |  <p>Example: input 4 (terminal 8) contact-operated</p> <table border="1"> <thead> <tr> <th>Input</th> <th>Terminal</th> </tr> </thead> <tbody> <tr> <td>1</td> <td>11</td> </tr> <tr> <td>2</td> <td>10</td> </tr> <tr> <td>3</td> <td>9</td> </tr> <tr> <td>4</td> <td>8</td> </tr> <tr> <td>5</td> <td>7</td> </tr> <tr> <td>6</td> <td>6</td> </tr> <tr> <td>7</td> <td>5</td> </tr> </tbody> </table> | Input | Terminal | 1 | 11 | 2 | 10 | 3 | 9 | 4 | 8 | 5 | 7 | 6 | 6 | 7 | 5 |
| Input | Terminal | | | | | | | | | | | | | | | | | | |
| 1 | 11 | | | | | | | | | | | | | | | | | | |
| 2 | 10 | | | | | | | | | | | | | | | | | | |
| 3 | 9 | | | | | | | | | | | | | | | | | | |
| 4 | 8 | | | | | | | | | | | | | | | | | | |
| 5 | 7 | | | | | | | | | | | | | | | | | | |
| 6 | 6 | | | | | | | | | | | | | | | | | | |
| 7 | 5 | | | | | | | | | | | | | | | | | | |

5 Function check

6 Device replacement / software update

If you need to replace the device or update the software, this chapter will help you back up and restore all necessary settings and parameters.

* Fill in this page before replacing the device.

Proof of service

Order number : _____
 Date : _____
 Device designation : _____
 Production number : _____

Activity

| | | done | |
|----|--|------|----|
| | | yes | no |
| 1. | Save measurement data to CF card or through the PCC software. | | |
| 2. | Save configuration data (setup) to CF card or through the setup software. | | |
| 3. | If used, save reports to CF card. Please note: reports cannot be terminated through the PC software. | | |
| 4. | If used, read out counter values with the setup software and write them down. Counter 1 : _____ Counter 2 : _____ Ext. counter 1 : _____ Ext. counter 2 : _____ | | |
| 5. | Read off IP address, Subnet-Mask and Gateway on the device or through the setup software and write them down. IP address : _____ . _____ . _____ . _____ Subnet-Mask : _____ . _____ . _____ . _____ Gateway : _____ . _____ . _____ . _____ | | |
| 6. | Read off values for fine calibration for all analog inputs on the device and write them down. Start act. / Start targ./ End act. / End targ. Analog input 1 : _____ / _____ / _____ / _____ Analog input 2 : _____ / _____ / _____ / _____ Analog input 3 : _____ / _____ / _____ / _____ Analog input 4 : _____ / _____ / _____ / _____ Analog input 5 : _____ / _____ / _____ / _____ Analog input 6 : _____ / _____ / _____ / _____ Analog input 7 : _____ / _____ / _____ / _____ Analog input 8 : _____ / _____ / _____ / _____ Analog input 9 : _____ / _____ / _____ / _____ Analog input 10 : _____ / _____ / _____ / _____ Analog input 11 : _____ / _____ / _____ / _____ Analog input 12 : _____ / _____ / _____ / _____ | | |

6 Device replacement / software update

Analog inputs (channels 1 – 12)

Thermocouple

| Designation | Type | Standard | Range | Linearization accuracy ¹ |
|--------------------------------------|--|-----------|-----------------|-------------------------------------|
| Fe-Con | L | DIN 43710 | -200 to +900°C | ±0.1% |
| Fe-Con | J | EN 60584 | -210 to +1200°C | ±0.1% above -100°C |
| Cu-Con | U | DIN 43710 | -200 to +600°C | ±0.1% above -150°C |
| Cu-Con | T | EN 60584 | -270 to +400°C | ±0.15% above -150°C |
| NiCr-Ni | K | EN 60584 | -270 to +1372°C | ±0.1% above -80°C |
| NiCr-Con | E | EN 60584 | -270 to +1000°C | ±0.1% above -80°C |
| NiCrSi-NiSi | N | EN 60584 | -270 to +1300°C | ±0.1% above -80°C |
| Pt10Rh-Pt | S | EN 60584 | -50 to +1768°C | ±0.15% above 0°C |
| Pt13Rh-Pt | R | EN 60584 | -50 to +1768°C | ±0.15% above 0°C |
| Pt30Rh-Pt6Rh | B | EN 60584 | 0 to 1820°C | ±0.15% above 400°C |
| Chromel-Copel | | | -200 to +800°C | ±0.15% |
| Shortest span | L, J, U, T, K, E, N, Chromel-Copel: S, R, B: | | | 100°C 500°C |
| Range start/end | freely programmable within the limits in 0.1°C steps | | | |
| Cold junction | Pt100 internal or thermostat external constant | | | |
| Cold junction accuracy (internal) | ± 1°C | | | |
| Cold junction temperature (external) | -50 to +100°C adjustable through setup software | | | |
| Sampling cycle | 6 or 12 channels 125msec | | | |
| Input filter | 2nd order digital filter; filter constant adjustable from 0 to 10.0sec | | | |
| Test voltage | 500V (across optocoupler) | | | |
| Resolution | > 14 bit | | | |
| Features | also programmable in °F | | | |

1. The linearization accuracy refers to the maximum span.
The linearization accuracy is reduced for shorter spans.

Resistance thermometer

| Designation | Standard | Connection | Range | Linearization accuracy | Measuring current |
|-------------|----------|------------|----------------|------------------------|-------------------|
| Pt 100 | EN 60751 | 2/3-wire | -200 to +500°C | ±0.4°C | 500µA |
| | | 2/3-wire | -200 to +850°C | ±0.8°C | 250µA |
| | | 4-wire | -200 to +500°C | ±0.4°C | 500µA |
| | | 4-wire | -200 to +850°C | ±0.5°C | 250µA |
| Pt 100 | JIS | 2/3-wire | -200 to +500°C | ±0.4°C | 500µA |
| | | 2/3-wire | -200 to +650°C | ±0.8°C | 250µA |
| | | 4-wire | -200 to +500°C | ±0.4°C | 500µA |
| | | 4-wire | -200 to +650°C | ±0.5°C | 250µA |
| Pt 500 | EN 60751 | 2/3-wire | -200 to +500°C | ±0.4°C | 250µA |
| | | 2/3-wire | -200 to +850°C | ±0.8°C | 250µA |
| | | 4-wire | -200 to +500°C | ±0.4°C | 250µA |
| | | 4-wire | -200 to +850°C | ±0.5°C | 250µA |
| Pt 1000 | EN 60751 | 2/3-wire | -200 to +500°C | ±0.4°C | 500µA |
| | | 2/3-wire | -200 to +850°C | ±0.8°C | 250µA |
| | | 4-wire | -200 to +500°C | ±0.4°C | 500µA |
| | | 4-wire | -200 to +850°C | ±0.5°C | 250µA |
| Ni 100 | EN 60751 | 2/3-wire | -60 to +180°C | ±0.4°C | 500µA |
| | | 4-wire | -60 to +180°C | ±0.4°C | 500µA |

7 Technical data

| Designation | Standard | Connection | Range | Linearization accuracy | Measuring current |
|------------------------|----------|---|---------------|------------------------|-------------------|
| Cu 50 | | 2/3-wire | -50 to +100°C | ±0.5°C | 500µA |
| | | 2/3-wire | -50 to +200°C | ±0.9°C | 250µA |
| | | 4-wire | -50 to +100°C | ±0.5°C | 500µA |
| | | 4-wire | -50 to +200°C | ±0.6°C | 250µA |
| Connection type | | 2-, 3- or 4-wire circuit | | | |
| Shortest span | | 15°C | | | |
| Sensor lead resistance | | max. 30Ω per core for 3-/4-wire circuit max. 10Ω per core for 2-wire circuit | | | |
| Range start/end | | freely programmable within the limits in 0.1°C steps | | | |
| Sampling cycle | | 6 or 12 channels 125msec | | | |
| Input filter | | 2nd order digital filter; filter constant adjustable from 0 to 10sec | | | |
| Test voltage | | 500V (across optocoupler) | | | |
| Resolution | | > 14bit | | | |
| Features | | also programmable in °F | | | |

Resistance transmitter and potentiometer

| Range | Accuracy | Measuring current |
|------------------------|----------|--|
| up to 180Ω | ±150mΩ | 500µA |
| up to 390Ω | ±300mΩ | 250µA |
| up to 2000Ω | ±2Ω | 500µA |
| up to 4000Ω | ±4Ω | 250µA |
| Connection type | | resistance transmitter: 3-wire circuit potentiometer: 2-/3-wire circuit |
| Shortest span | | 6Ω |
| Sensor lead resistance | | max. 30Ω per core for 4-wire circuit max. 20Ω per core for 2- and 3-wire circuit up to 200Ω range: max. 10Ω per core for 2- and 3-wire circuit |
| Resistance values | | freely programmable within the limits in 0.1Ω steps |
| Sampling cycle | | 6 or 12 channels 125msec |
| Input filter | | 2nd order digital filter; filter constant adjustable from 0 to 10.0sec |

Input for DC voltage, DC current

| Basic range | Accuracy | Input resistance |
|-----------------|----------|---|
| -20 to +70mV | ±80µV | $R_{IN} \geq 1\text{ M}\Omega$ |
| -5 to +105mV | ±100µV | $R_{IN} \geq 1\text{ M}\Omega$ |
| -10 to +210mV | ±240µV | $R_{IN} \geq 1\text{ M}\Omega$ |
| -0.5 to +12V | ±6mV | $R_{IN} \geq 470\text{ k}\Omega$ |
| -0.05 to +1.2V | ±1mV | $R_{IN} \geq 470\text{ k}\Omega$ |
| -1.2 to +1.2V | ±2mV | $R_{IN} \geq 470\text{ k}\Omega$ |
| -12 to +12V | ±12mV | $R_{IN} \geq 470\text{ k}\Omega$ |
| Shortest span | | 5mV |
| Range start/end | | freely programmable within the limits (up to 999mV in 0.01 mV steps, above 1V in 1 mV steps) |
| -2 to +22mA | ±20µA | burden voltage ≤ 1V |
| -22 to +22mA | ±44µA | burden voltage ≤ 1V |
| Shortest span | | 0.5mA |

7 Technical data

| | |
|-----------------|--|
| Range start/end | freely programmable within the limits in 0.1 mA steps |
| Sampling cycle | 6 or 12 channels 125msec |
| Input filter | 2nd order digital filter; filter constant adjustable from 0 to 10.0sec |
| Feature | adjustable linearizations for thermocouples and resistance thermometers (for connection of transmitters without linearization) |

Transducer short-circuit/break

| | Short-circuit ¹ | Break ¹ |
|------------------------|----------------------------|--------------------|
| Thermocouple | not detected | detected |
| Resistance thermometer | detected | detected |
| Resistance transmitter | detected | detected |
| Potentiometer | not detected | detected |
| Voltage up to $\pm 1V$ | not detected | detected |
| Voltage $> \pm 1V$ | not detected | not detected |
| Current | not detected | not detected |

1. programmable reaction of instrument, e.g. triggering alarm

Logic inputs (extra code)

| | |
|----------------|---|
| Number | 7 to DIN VDE 0411, Part 500; max. 25Hz, max. 32V |
| Level | logic "0": -3 to +5V, logic "1": 12 to 30V |
| Sampling cycle | minimum 1 sec |

Outputs

| | |
|--------------------------------------|--------------------------------------|
| 1 relay (ex-factory) | changeover, 3A, 230V AC ¹ |
| 4 relays (extra code) | make/break, 3A, 230V AC ¹ |
| 1 open-collector output (extra code) | max. 25V, max. 100mA |
| 1 voltage output (extra code) | 24V DC, 50mA |

1. with resistive load. SELV circuits and supply circuits must not be combined.

Screen

| | |
|------------------|------------------|
| Resolution | 320 x 240 pixels |
| Size | 5.7" |
| Number of colors | 27 colors |

7 Technical data

Electrical data

| | |
|---|---|
| Supply (switch-mode power supply) | 110 – 240V AC +10/-15%, 48 – 63Hz or 20 – 30V AC/DC, 48 – 63Hz |
| Electrical safety | to EN 61 010, Part 1 of August 2002 overvoltage category II, pollution degree 2 |
| Test voltages (type test) - mains supply circuit to measuring circuit - mains supply circuit to housing (protective conductor) - measuring circuits to measuring circuit and housing - electrical isolation between the analog inputs | with AC supply: 3.7kV/50Hz, 1 min, with AC/DC supply: 510V/50Hz, 1 min with AC supply: 2.3kV/50Hz, 1 min, with AC/DC supply: 510V/50Hz, 1 min 510V/50Hz, 1 min up to 30V AC and 50V DC |
| Supply voltage error | < 0.1 % of range span |
| Power consumption | approx. 25VA |
| Electrical connection | at rear by plug-in screw terminals, max. conductor cross-section 2.5mm ² or 2x 1.5mm ² with ferrules |

Environmental influences

| | |
|--|--|
| Ambient temperature range | 0 to +45°C |
| Ambient temperature error | 0.03% per °C |
| Storage temperature range | -20 to +60°C |
| Climatic conditions | ≤ 75% rel. humidity, no condensation |
| EMC - interference emission - immunity to interference | EN 61 326 Class A to industrial requirements |

Housing

| | |
|--------------------|---|
| Housing front | zinc die-casting or stainless steel |
| Housing type | panel-mounting housing to DIN 43 700, galvanized steel sheet |
| Bezel size | 200mm x 144mm |
| Depth behind panel | 225mm |
| Panel cut-out | 138 ^{+1.0} mm x 138 ^{+1.0} mm |
| Housing fixing | in panel to DIN 43 834 |
| Operating position | unrestricted, taking into account the viewing angle of the screen, horizontal ±50°, vertical ±30° |
| Protection | to EN 60 529 Category 2, front IP54 (IP65 with extra code stainless steel front), rear IP20 |
| Weight | approx. 3.5kg |

A

Accessories *11*
Analog inputs *17*
Arrangement of the documentation *6*

B

Back panel *17*

C

Climatic conditions *13*
Commissioning *5*
CompactFlash *16*
Connection diagram *17*
Cover for back panel *17*

D

Digital I/O *19–20*

E

Electrical connection *15*
Electrostatic discharge (ESD) *5*

F

Fitting into the panel *14*
Function check *21*

I

Identification of namplate *9*
Installation *13*
Installation notes *15*
Instrument documentation in printed form *6*
Instrument documentation in the form of PDF files *6*
Instrument version, identification of *9*
Interfaces *18–19*
Introduction *5*

L

Location *13*

M

Mounting in position *13*

N

Nameplate *9*

Note signs *7*

O

Outline drawings *13*

P

PROFIBUS-DP *19*

R

Rear view *17*

Relay outputs *19*

Returning *5*

S

Sales documentation in printed form *6*

Stainless steel *16, 28*

Standard accessories *11*

Start screen *21*

Supply *17*

T

Technical data *25*

Type designation *10*

Typographical conventions *7*

V

Visualization level *21*

W

Warning signs *7*

Warranty *5*

11.04/00437662

Subject to alterations without notice.
Bei Änderungen erfolgt keine Mitteilung.
Modifications sans avertissement réservées.

© PMA Prozeß- und Maschinen-Automation GmbH
Postfach 310 229, D - 34058 Kassel
Printed in Germany 9499 040 76011 (0412)

A5

A5, geheftet, SW-Druck, Normalpapier 80g weiß